



# CRANE ATTACHMENTS

## PALLET FORKS

MANUAL AND SELF LEVELING



HC10096-M54  
MANUAL FORK



HC10097-54  
SELF LEVELING FORK



PROUDLY MADE  
IN THE U.S.A.

## FEATURES PALLET FORKS

### HC10096-M54 Manual Fork

- 6,000 lb capacity
- 46" long tines (24" CG)
- Manual level adjustment
- Weight: 405 lb

### HC10097-54 Self Leveling Fork

- 6,000 lb capacity Includes attachment wt
- 46" long tines (24" CG)
- Self levels at any weight
- Gas springs virtually maintenance free
- Weight: 420 lb



# PALLET FORKS

HC10096-M54 / HC10097-54

HC10096-M54  
MANUAL FORK

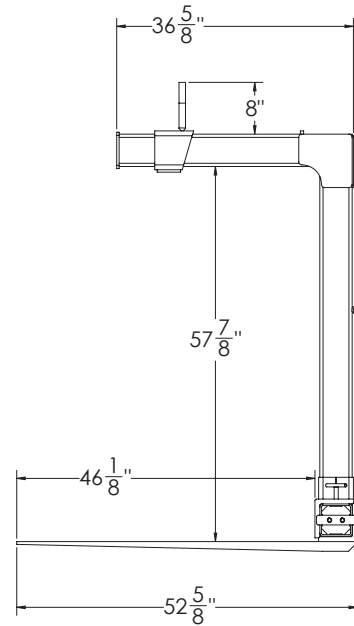
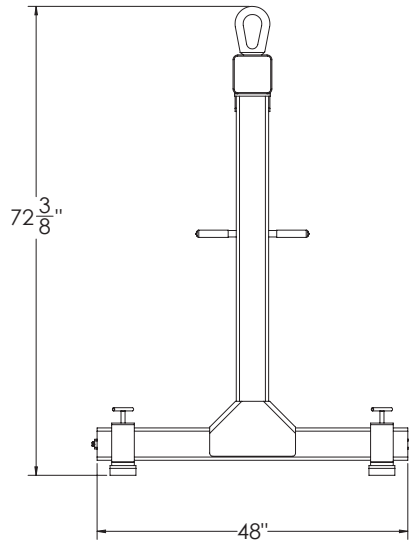

HC10097-54  
SELF LEVELING FORK

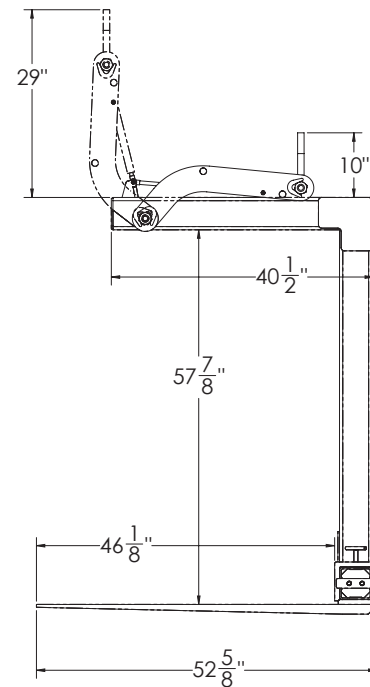
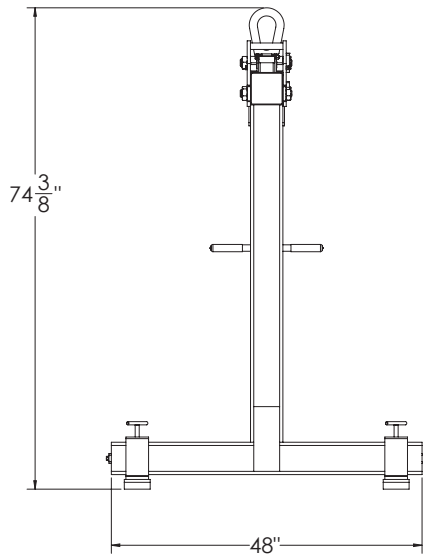

\*Heiden Inc., reserves the right to change these specifications without notice and without incurring any obligation relating to such changes.

OUR RELIABILITY, DELIVERY, AND INTERCHANGEABLE CUSTOM DESIGNS WILL IMPROVE YOUR BOTTOM LINE.



Interchangeable  
Components



Exceptional  
Durability



Fast  
Turnaround



Made in  
USA

4624 Expo Dr. Manitowoc, WI 54220  
 Toll Free: 888.682.5779 Phone: 920.682.6111  
 Fax: 920.682.3174  
 Email: heiden@heidenco.com

[HEIDENCRANE.COM](http://HEIDENCRANE.COM)



HEIDEN, INC IS AN ISO 9001-2015 CERTIFIED COMPANY



PROUDLY MADE IN THE U.S.A.