

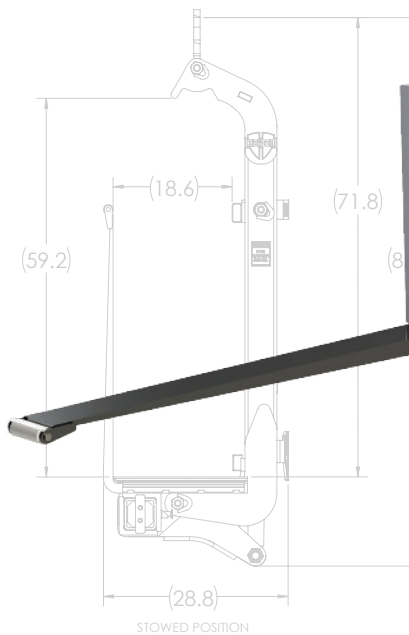

CRANE ATTACHMENTS

WALLBOARD FORK

HCF-M

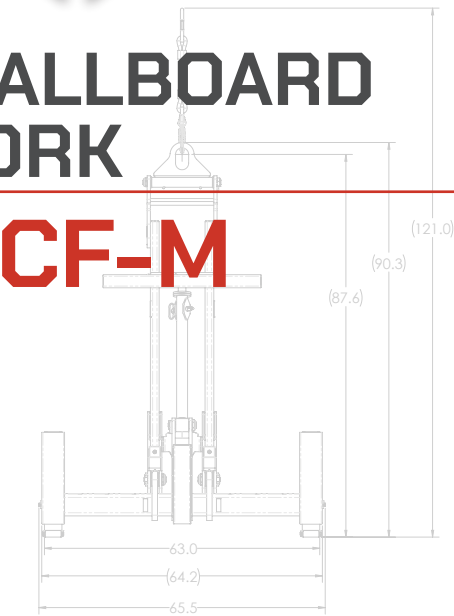

MULTIPLE MODELS AVAILABLE

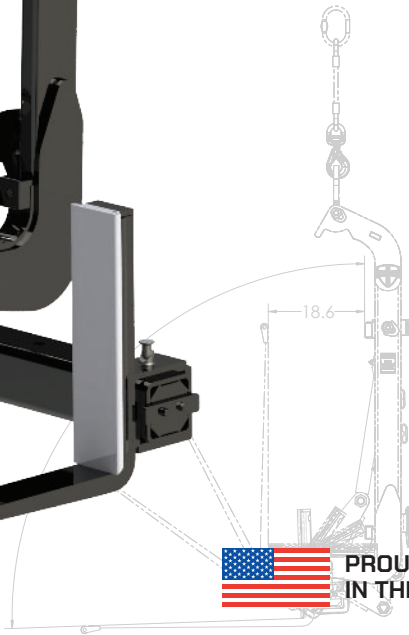

PROUDLY MADE IN THE U.S.A.

FEATURES

HCF WALLBOARD FORK SERIES

- Heiden exclusive
- Mechanical operation
- Simple to use
- Backstop available
- 63" & 72" wide models

- No batteries or hydraulics
- 6,000 Lb capacity Includes attachment wt
- Lower cost replacement parts
- No minimum order quantity



HCF WALLBOARD FORK SERIES

HCF-5463 / HCF-5472

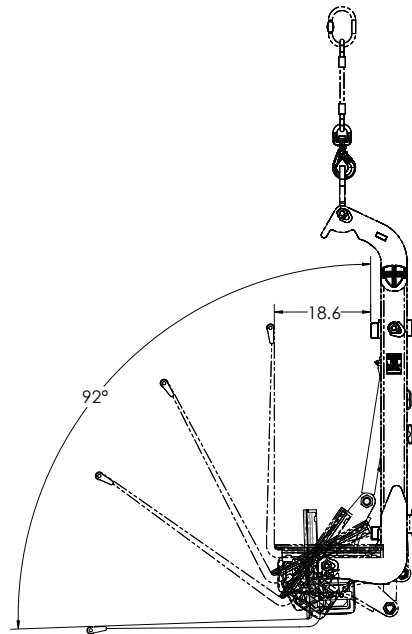
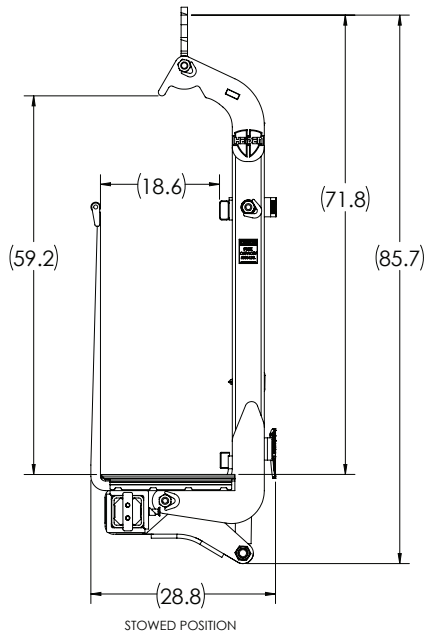
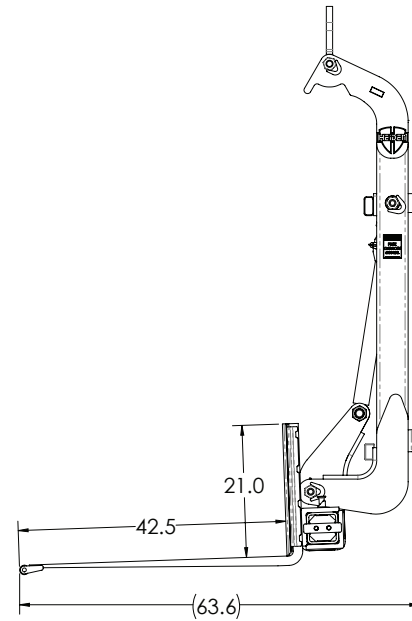
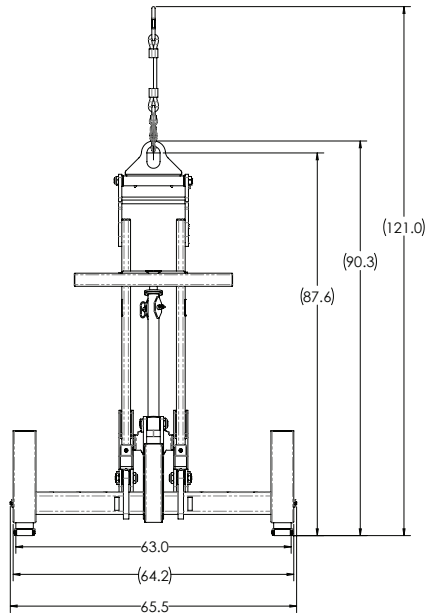

*Heiden Inc., reserves the right to change these specifications without notice and without incurring any obligation relating to such changes.

OUR RELIABILITY, DELIVERY, AND INTERCHANGEABLE CUSTOM DESIGNS WILL IMPROVE YOUR BOTTOM LINE.



Interchangeable Components



Exceptional Durability



Fast Turnaround



Made in USA

4624 Expo Dr. Manitowoc, WI 54220
 Toll Free: 888.682.5779 Phone: 920.682.6111
 Fax: 920.682.3174
 Email: heiden@heidenco.com

HEIDENCRANE.COM



HEIDEN, INC IS AN ISO 9001-2015 CERTIFIED COMPANY



PROUDLY MADE IN THE U.S.A.