



# CRANE ATTACHMENTS

## WALLBOARD FORK

## HCF SERIES

MULTIPLE  
MODELS  
AVAILABLE



PROUDLY MADE  
IN THE U.S.A.

### FEATURES

### HCF WALLBOARD FORK SERIES

- 6,000 Lb capacity
- 360 Continuous rotation with integrated brake
- "Twist-n-lock" tine locks
- Compatible link included
- Load holding hydraulic cylinder

- Custom colors available
- Lower cost replacement parts
- Weight: 920 lb
- No minimum order quantity
- 2-Week lead time





# HCF WALLBOARD FORK SERIES

HCF-5463 / HCF-5472 / HCF-5484 / HCF-5463-22 / HCF-5472-22 / HCF-5484-22

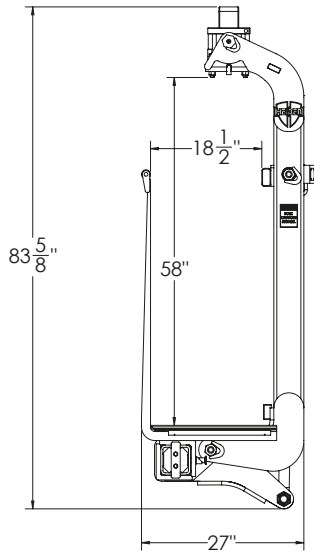
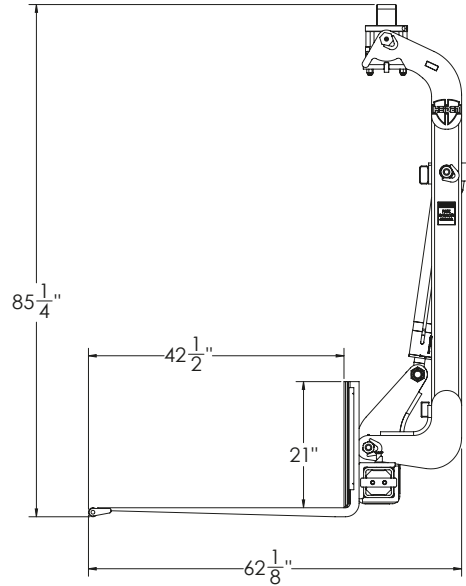
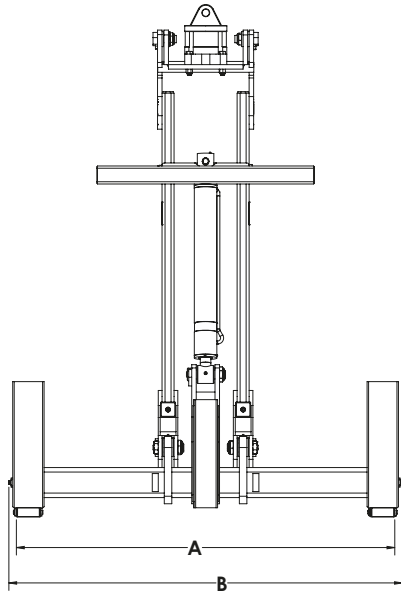

STOWED POSITION

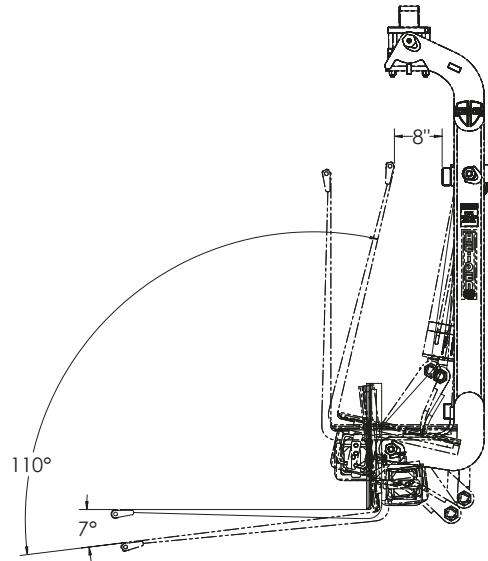

\*Heiden Inc., reserves the right to change these specifications without notice and without incurring any obligation relating to such changes.

OUR RELIABILITY, DELIVERY, AND INTERCHANGEABLE CUSTOM DESIGNS WILL IMPROVE YOUR BOTTOM LINE.



Interchangeable Components



Exceptional Durability



Fast Turnaround



Made in USA

4624 Expo Dr. Manitowoc, WI 54220  
Toll Free: 888.682.5779 Phone: 920.682.6111  
Fax: 920.682.3174  
Email: heiden@heidenco.com

[HEIDENCRANE.COM](http://HEIDENCRANE.COM)



HEIDEN, INC IS AN ISO 9001-2015 CERTIFIED COMPANY



PROUDLY MADE IN THE U.S.A.